



# PRODUCT CATALOGUE

## 2023



**engcon**<sup>®</sup>



# Into the future with engcon

We met many satisfied engcon customers at BAUMA, the major German equipment exhibition, in October 2022. Thanks to our innovation-driven work that focuses on the end customer, engcon can be depended on to deliver state-of-the-art technology at all times. Our package provides a safe total solution and our customers' preferred premium product today, tomorrow and into the future. Do you want to be part of the future and help us change the world of digging? Read more in the catalogue and contact your dealer today.

We manufacture a wide range of tools to make your work as efficient as possible. This year, we added a detachable rotating brush model in the 4-6 tonne excavator range, suitable for the S40 hitch. With engcon's quick hitches it's ready to take both the detachable gripper cassette and detachable rotating brush, making work easier in those hard-to-reach areas like building drainage and cable trenching. Find out more on page 4.

## Improvements

We constantly work on product improvement. This is where good contact with the customer is essential. By keeping an ear to the ground, we stay one step ahead and develop products that meet your needs. We have incorporated stronger material in the drive shaft, improved the grease points and reinforced the lift cylinder attachment point in our larger detachable rotating brushes, all in the name of providing our customers with improved performance.

## Total solution

When you purchase an engcon product you're not only getting the latest technology, we also provide you with a total solution and access to our highly valued customer support. Feedback tells us our support staff are knowledgeable, solution-oriented and professional. You already knew that engcon saves you time and money, and our flexible support staff will save even more of your precious time.



engcon Environmental Certification  
SS-EN ISO 14001:2004



engcon Quality Certification  
SS-EN ISO 9001:2008

*engcon is not responsible for any printing errors.  
The illustrations in the catalogue show typical  
configurations.*

*Technical data may vary. We reserve the right to  
make changes without prior notice.*



# CHANGE THE WORLD OF DIGGING



## Contents

4	New product 2023	
6	EC-Oil	
10	Service friendly modular system	
12	Profitable freedom of choice	
14	Tiltrotators	
20	Quick hitch	
22	Locking system	
24	Quick hitches	
25	Attachment brackets	
	GS40-ECO-GS80-ECO	25
	GS30-GS80	25
26	Detachable gripper	
27	Detachable rotating brush	
28	Integrated gripper	
29	Hydraulic tools	
	Stone and sorting grapple	29
	Timber/combi grapple	30
	Rotating brush	30
	Pallet fork	31
	Compactor	32
34	Mechanical tools	
	Grading beam	34
	Cable bucket	34
	Deep-digging bucket	35
	Sorting bucket	35
	Grading bucket	36
	Water & sewerage bucket	36
	Gripper-adapted bucket series	36
	Asphalt cutter	37
	Ripper	37
38	Optional extra	
	Joysticks	38
	Control system	40
	engcon Positioning System	41
42	Technical data	

# Detachable rotating brush for the 4-6 tonne excavator range – suitable for S40 hitches

We're introducing a detachable rotating brush for 4-6 tonne excavators with S40 hitches. It's versatile and useful for tasks like building drainage and cable trenching, especially in hard-to-reach areas. It allows for easy sweeping of 4 inches at a time when using the cable bucket on the quick hitch, reducing the need for manual labor and minimizing the risk of damage to underground cables.

This detachable rotating brush, is also available for S45 and S60 models and can be easily retrofitted to the quick hitch by hooking onto the two hitch hooks.

The brush is locked and connected to the hydraulics in a simple, quick and easy operation. It is driven by a powerful hydraulic motor and folded up or down with a hydraulic cylinder.

It minimizes the need for manual labor and contributes to a safer work site. Safety is a priority for engcon.



Read more about our detachable rotating brushes at page 27



# EC-Oil automatic quick hitch for tiltrotators in the 4–33 tonne weight classes

## Characteristics:

- + The EC-Oil automatic quick hitch system on the upper and lower sections is standard.
- + Ready for a detachable gripper
- + Tilt & rotation sensors are standard for connection to machine control
- + Extra hydraulic socket for hydraulic tool connection even when EC oil is connected
- + Central lubrication (a single grease point for the entire tiltrotator; can also be connected to the excavator's central lubrication system)
- + Load-holding valves on tilt cylinders as standard for even better safety
- + Hardened piston rods
- + Up to  $\pm 45$ -degree tilt angle for best access



Read more about EC-Oil on page 6

# Switch jobs in an instant – from the cab

EC-Oil, allows for quick switching of hydraulic tools and connection/disconnection of the tiltrotator for increased breakout force. The EC-Oil automatic hydraulic connector is now standard, potentially saving an hour or more daily compared to manual connection, increasing efficiency.

As a supplier we can help you with a total solution – everything from control systems, machine hitches, tiltrotators and associated tools. Use EC-Oil for instant tool and attachment changes directly from the cab. With EC-Oil on the machine hitch, above and below the tiltrotator and on the tool itself, you can disconnect from the tiltrotator and connect the machine hitch directly to a hydraulic or mechanical tool whenever you need extra breakout force.

This also saves weight, which means fuel savings and improved total efficiency. Together they create a system of tools that allow you to work quickly, efficiently and profitably. EC-Oil is designed for the highest operational reliability in demanding environments. The EC-Oil™ has no visible hoses or electrical cables that move around when connecting. This reduces the risk for pinch damage and wear. The engcon quick hitch system handles the connection of pressurised tools at full system pressure.

The proprietary oil and electrical connections are designed to be even better at withstanding the tough conditions excavators often have to work in. The connectors are designed for tough handling, as proven through destructive testing at 1600 bar operating pressure and field tests in difficult environments. EC-Oil™ also connects to central lubrication automatically.

## EC-Oil™



EC-Oil block with:

1. Electrical connector, 12 pole
2. Two oil connectors (supply and return)
3. Central lubrication

## EC-Oil in a nutshell

- » EC-Oil is standard with all purchases of engcon machine hitches and tiltrotators.
- » This lets you change hydraulic tools in around ten seconds without leaving the cab
- » Connects hydraulic tools automatically
- » Can be retrofitted to all types of hydraulic tools, regardless of manufacturer\*
- » Requires no installation for return oil
- » Extremely durable connectors allow tool connection at full system pressure
- » Drip-free system = Lower environmental impact
- » Reduces problems with manual hydraulic connectors

\* Check specifications and flow requirements.

## Calculate your savings

If nothing goes wrong, connecting a tool manually takes around 90 seconds. With EC-Oil, the same tool change takes about 10 seconds. The number of times we switch attachments naturally varies, but certain tasks require around 50 tool changes a day. On days like that, EC-Oil will save you more than one hour of labour!

## Automatic quick hitch system – our standard

When you order an engcon S40-S80 machine hitch we include the EC-OIL automatic oil connector in the machine hitch, the upper section of the tiltrotator, and in the tiltrotator quick hitch (S40-S80).

EC-Oil is ALWAYS included as standard, on all engcon hydraulic tools with S40-S80.

EC-Oil block with  
drain line









# engcon's automatic hydraulic hitches

## Connect without leaving the cab:

Use the machine hitch and the tiltrotator (1) or disconnect the tiltrotator and connect your tools directly to the machine hitch when you need maximum breakout force or lifting capacity (2). All without leaving the cab!



**EC-Oil™**

## engcon Hydraulic tools



Stone and  
sorting grapples



Combi  
grapples



Ground  
compactor



Pallet fork/  
pallet forks



Rotating  
brushes

## engcon Mechanical tools

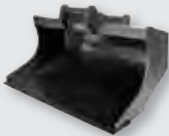

Grading  
bucket



Deep-digging  
bucket



Sorting bucket



Water &  
sewerage  
bucket



Cable  
bucket



Ripper



Asphalt  
cutter



Grading  
beam

**CHANGE  
THE WORLD OF  
DIGGING**

SERVICE FRIENDLY MODULAR SYSTEM AND HIGH-FLOW SWIVEL

## Makes the tiltrotator lighter, allows higher flows and requires less maintenance

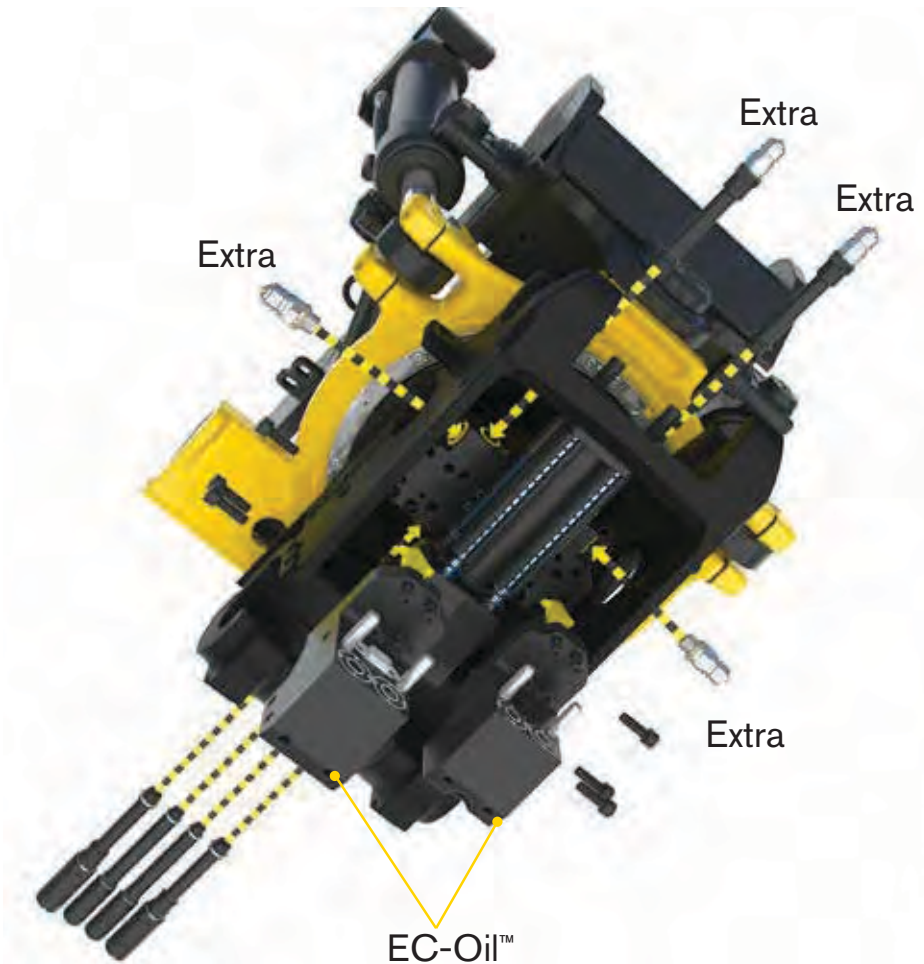

The service friendly design provides superb simplicity and an uncluttered quick hitch. Because the block is bolted on without the need for hose runs, retrofitting engcon's EC-Oil automatic oil connection system is now simple. And it's just as easy to install and retrofit EC-Oil to engcon's new retrofittable, detachable gripper cassette and rotating brush.

### New high-flow swivel

In parallel with the creation of the new modular quick hitch, engcon has developed a new high-flow swivel that permits hydraulic flows up to 200 l/min. This is achieved by feeding the hydraulic functions directly without oil having to pass through the tiltrotator's valves. The new high-flow swivel

also has a separate case drain line, which allows oil to be drained via the tiltrotator. What's more, engcon's new swivel is built for pressures up to 350 bar.

### Modular construction

This development is part of our unique modular approach in which we offer a basic product allowing our customers to easily add functions later without having to run hoses inside the hitch. We also minimise the problems with hoses moving around in the quick hitch, with the risk of chafing and leaking over time.







PROFITABLE FREEDOM OF CHOICE

# Build your own bespoke system with engcon



## Standardised locking system

For safe quick hitch operation.



## Joystick

Select now or add later (fits all makes and types of control systems).



## Control system

Select now or add a smartphone later for remote support.

## engcon Positioning System

Sensors are included as standard on EC214 to EC233. Available as optional extras on EC206 & EC209.



## Quick hitch

Safe, smart and service-friendly quick hitch without moving parts; developed for detachable grippers and rotating brushes, and the EC-Oil automatic quick hitch system.



Detachables  
Gripper



Detachables  
rotating  
brush



**EC-Oil**



## Automatic machine hitch excavator

The EC-Oil automatic oil, power and central lubrication connection system is standard on our automatic machine hitches.

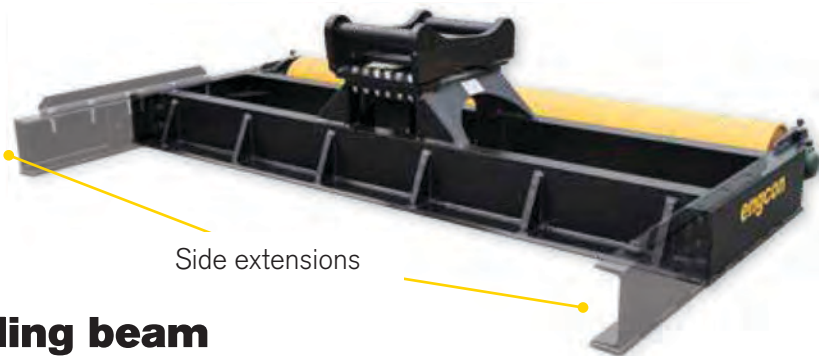

Side extensions

## Grading beam

Add now or select side extensions later.

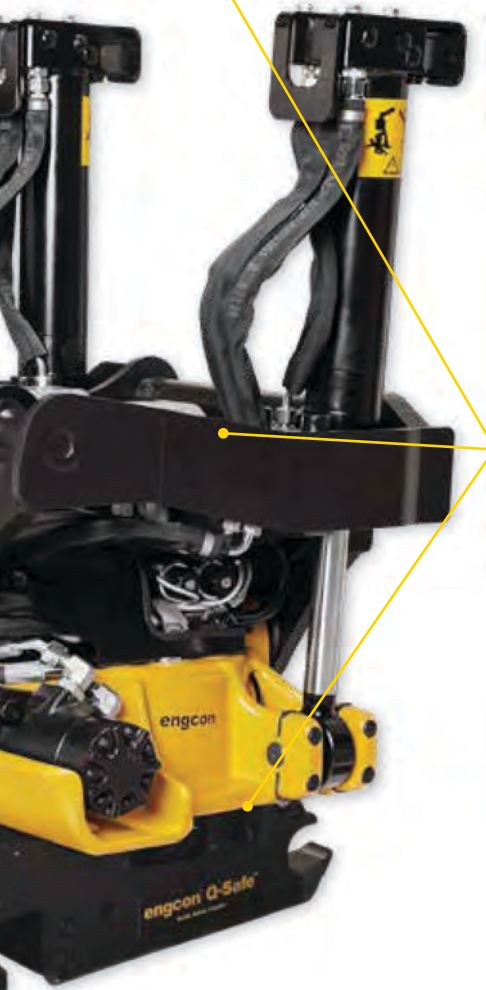

## EC-Oil | Quick tool changes

The EC-Oil automatic oil, power and central lubrication connection system is standard.



**EC-Oil**  
STANDARD

Read more on  
page 6



## Bracket | Bolt-on

Compactors, sorting grapples, grading beams, timber/combi grapples, rotating brushes – bolt-on bracket for easy hitch system replacement



# Tiltrotators

engcon's tiltrotators can be adapted to most excavators and backhoe loaders on the market, with machine weights of 1.5-33 metric tons.

## engcon's standard

engcon's tiltrotators are robustly built to a very high standard, and we provide the customer with many opportunities to select accessories right away or for retrofit. If you choose to retrofit, we've made it easy as in most cases it's just a matter of 'bolting on' the accessory afterwards – be it one week or one year later.

All engcon S40-S70 quick hitches are ready for our detachable gripper and rotating brush. This means you can buy your tiltrotator without a gripper and retrofit one whenever it suits you. All of our tiltrotators from the EC206 and up are equipped with tilt and rotation sensors.

## The following are standard on engcon tiltrotators

- » The EC-Oil automatic oil connection system comes as standard on tiltrotators\*
- » Prepared for detachable gripper, S40-S70
- » Prepared for rotating brush, S40, S45 and S60
- » Prepared for engcon's standardized locking system to minimise risks with wrongly connected or dropped buckets
- » Comes ready for a rotation sensor for connection to an excavator guidance system (from EC206 and higher)
- » Up to  $\pm 45$ -degree tilt angle for best access
- » Powerful tilting torque for heavy-duty jobs
- » Flows of up to 120 l/min on extra hydraulic outlets (from EC214 to EC233)
- » Direct feed from the machine can provide 200 l/min (EC214 to EC233)
- » Central lubrication
- » Load-holding valves on tilt cylinders for even better safety
- » Hardened piston rods
- » 2-year warranty

## Control

- » Control system remote support via smartphone app
- » The ability to operate 6 rollers simultaneously
- » Track/wheel control
- » Control, VA boom, outriggers & blade
- » Joystick wrist support for increased comfort and best ergonomics

\* Read more on page 6



engcon provides a two-year warranty on all new tiltrotators. We also offer the opportunity to register your tiltrotator and log service carried out.



**EC02**  
1.5-2.5 tonnes



**EC204**  
2-4 tonnes



**EC206**  
4-6 tonnes



**EC209**  
6-9 tonnes



### The advantages of engcon tiltrotators

- » Tilt cylinders equipped with load-holding valves as standard equipment (requirement for pallet fork operations)
- » Protected hydraulic connections
- » Fitted with tight hose protection that prevents oil from spraying out, for example in the event of a hose failure
- » Robust tilt upper section with EC-Oil automatic oil, power and central lubrication connection system.  
Compatible with S40 and higher
- » Tilt angle up to 45 degrees
- » Strong upper sections
- » Low height
- » Suitable for use with the engcon proportional control system and joysticks
- » Comes ready for tilt-sensor for most excavator guidance systems\*\*
- » Comes ready for Auto-Tilt\*\*\*
- » All grease points routed to a single grease point. Easy to connect to the excavator's central lubrication
- » Comes ready for connection to any excavator guidance system\*\* (Compatible with EC206 and higher.)
- » Hardened cylinder rods
- » Heavy-duty bearings for increased service life
- » Heavy tilt torque
- » High rotator torque
- » Robust cast body
- » Robust lower sections
- » Engineered for high breakout torque
- » Comes with a high-flow swivel with up to 120 l/min flow to extra hydraulics as standard
- » Direct feed from the machine can provide 200 l/min (EC214 and higher)
- » In its standard version, quick hitch S40-70 is suitable for retrofitting gripper cassettes
- » In its standard version, the S40-60 quick hitch is suitable for retrofitting rotating brushes
- » Unique, service-friendly design allows adjustment of lateral play without having to dismantle the tiltrotator



\* Applies with selection of S40-S80 tilt upper section.  
 \*\* Requires ePS and works with e.g. Leica Geosystems, Scanlaser, Topcon, Trimble, Novatron and MOBA (2017). Check compatibility with your excavator guidance system supplier.  
 \*\*\* Check compatibility with your excavator guidance system supplier.



### Tiltrotator storage and transport stand

The engcon storage and transport stand makes it easy to stand, store or transport your tiltrotators without the risk of damage or dirt in the lower quick hitch. The stand is built from heavy-duty plate and can be fitted with optional attachment points for bolting to the chassis. Its dimensions are those of a Europallet, 80 × 120 cm, and the stand is designed to be lifted by forks from the sides or ends.



**EC214**  
9-14 tonnes



**EC219**  
14-19 tonnes



**EC226**  
19-26 tonnes



**EC233**  
24-33 tonnes

SAVE MONEY, WORK MORE EFFICIENTLY

# Applications for your tiltrotator

## Pipelines, water mains and sewers

Digging ditches for water mains and sewers often involves working in confined spaces. In some cases, there's not even enough room to drive in or back out with the machine. The answer is an engcon tiltrotator – it will make your excavator more flexible than you ever could have dreamed of. A tiltrotator lets you dig at any angle, and you can excavate a manhole or a stop end without having to move the machine at all.

## Construction sites

Not only does an engcon tiltrotator make excavation per se so much more efficient and profitable thanks to the ability to angle and rotate the bucket into positions that were previously impossible, but it also minimises the number of machine movements and thus enhances safety around the machine while reducing damage to the land.

## Roadworks

Road construction involves many different tasks, and engcon's tiltrotators make the work a lot simpler. When you're ditching, removing topsoil, terracing, laying pipes or working with grippers, there's no need to move the machine.

## Railway work

Working with excavators on railways demands extremely high standards. Safety always comes first, and this is where engcon provides important solutions. The use of an engcon tiltrotator transforms your excavator into a flexible, efficient and SAFE tool carrier.

## Electrical work, telecoms and broadband

Excavation work in these areas is often associated with precision excavation in cramped locations and hard-to-get-at spaces. engcon tiltrotators are an elegant solution to such problems. Thanks to the ability to rotate and tilt the bucket, there's no need to constantly move the machine to gain access.

It also makes digging up existing cables easy. Rotate the bucket through 90 degrees and then tilt it to a suitable angle to excavate alongside, below or above an existing cable with the highest precision.

## Landscaping

No work demands as much precision and feel as landscape gardening. The land and local area must be shaped such that it blends into the surroundings. There are often no plans, so creating a beautiful, elegant landscape is an entirely up to you, your feeling and imagination.

TILTROTATORS –  
THE BENEFITS  
- **How to  
change the  
world of  
digging**



### Financial

Tiltrotators save time and cut down on fuel consumption. They also reduce the need for additional machines and labour. What's more, their precision and flexibility means less material wastage.



### Safety

Because of their high manoeuvrability and low space requirements, tiltrotators increase safety around the machine. They also significantly reduce the need for manual labour.





**engcon**<sup>®</sup>



**Flexibility**

A tiltrotator makes it easy to rotate and tilt the bucket regardless of machine position. In addition to ordinary buckets, the machine can also be fitted with many different types of tools and replace many other machines at one and the same site.



**Environmental impact**

Fewer excavator movements means less damage to the ground, significantly reducing its environmental impact thanks to lower fuel consumption. Because it's possible to excavate around obstacles and in confined spaces, there is less need to move objects that are in the way.



**Comfort and convenience**

A tiltrotator and EC-Oil automatic quick hitch system allows the operator to remain comfortably in control in his work environment as there is no longer any need to leave the cab to connect hydraulic tools.

# Select a gripper cassette or sweeper now or later

New quick hitch and smart accessories for safety and greater freedom of choice.

Have you ever bought a product and later regretted that you didn't buy that extra feature with its added advantages? Relax; engcon has solved the problem for you by making our quick hitches even smarter. With our S40-70 quick hitch on the tiltrotator, you can connect or disconnect your retrofittable gripper cassette, and detachable rotating brush on the S40-S60.

The technique involves engcon tiltrotators and S40-S70 quick hitches that have two robust hooks mounted at the front and space for extra hydraulics. This makes it easy to hook up engcon's retrofittable detachable gripper cassette or rotating brush.

## Gripper cassette - Gripper Detachable Quick

The gripper cassette simply hooks onto the quick hitch, whereupon the gripper cassette is locked on and the hydraulics connected in a single operation – a procedure that takes less than a minute.

## Rotating brushes - Rotating brush Detachable

As with the gripper cassette, the rotating brush can be retrofitted on the quick hitch by hooking onto the hitch's two attachment hooks. The rotating brush is then locked and connected to the hydraulics in a single quick and easy operation. Sweeper cassettes are fitted with mechanisms and hydraulics that facilitate changing in a single quick and easy operation. The sweeper is driven by a powerful hydraulic motor and is folded up or down with a hydraulic cylinder. Its extremely flexible design allows its width to be adjusted to accurately suit the work it has to do.

In its narrowest version, the sweeper can be adapted for e.g. cable sweeping, which facilitates excavation of existing cables or pipes – and most importantly, results in fewer cables or pipes being broken, as excavation is completed to a safe depth with the sweeper clearing away the rest. Thanks to our new rotating brushes, the need for manual labour is also minimized, which contributes to a safer work site. Safety is everything to us at engcon.

The wider version combined with a tiltrotator allows gravel or soil to be swept into the machine's bucket, making it easier to clear away material that has to be removed.

## A new level of safety

In addition to our giving operators increased options, we are also improving safety. The two sturdy hooks provide enhanced safety because they continue to hold the gripper cassette or rotating brush in place; even if the lock function should fail, the load or the gripper cassette or rotating brush's own weight will press it securely against the quick hitch.





## Quick hitch

Powerful suspension and stable locking on the engcon S40-S70 quick hitch and space for extra hydraulics enable the use of additional hydraulic attachments, such as engcon's new detachable gripper and rotating brush.

**News!** Narrow brush cassettes for cable trenching available as standard in 2023.

Detachable gripper



Detachable rotating brush

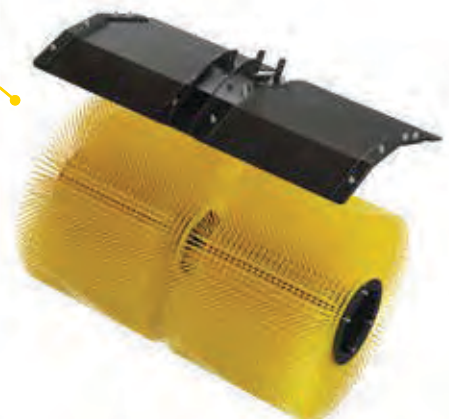

# engcon's automatic quick hitch

Hitch with its hooks facing the direction of excavation with a focus on safety

## Hooks facing the direction of excavation

Probably the only quick hitch where the hooks face the direction of excavation thus distributing the forces across the entire hitch. The hooks are also wedge-shaped to minimise play between the hitch and the tool.

## Minimise the risk of dropped buckets

The risk of dropped buckets and incorrectly connected tools due to the human factor has been minimised. That risk is minimised when engcon's quick hitch and standardised locking control is used on the excavator, as the bucket or tool must make ground contact.

With engcon's safe quick hitch for excavators, it's almost impossible to disconnect the bucket or tool while it is in mid-air.

## Stay in safe control when switching tools

Activate the lock function\*, apply light pressure to the ground with the bucket or tool, then disconnect the bucket or tool. If the engcon hitch loses contact with one of the bucket axles, the machine's slew function is locked. When both bucket axles are fully disconnected, the slew lock can be released.

## Connecting the bucket/tool

Activate the lock function\*, hook up the bucket or tool and lock it. The slew function is locked again when connecting the bucket or tool when the first axle reaches the hitch. Once the bucket/tool is properly locked, the slew lock can be lifted.

If the bucket/tool is not properly locked on both axles, the operator and people in the surroundings are alerted by audible and light warnings. The slew lock is also activated.

Once the bucket/tool is fully and correctly connected, the audible/light warning cease; the slew lock can now be lifted and the machine is ready to work with the bucket/tool safely and fully connected.

Read more about the engcon lock control on pages 22 and 23.

\* Read more about standardised lock control on pages 22 and 23

\*\* Read more about warning lights and sounds in the adjacent column

\*\*\* The ground pressure function requires the bucket/tool to exert pressure on the ground before it can be disconnected. The function is provided in combination with the engcon locking system.

Warnings system with sound and light alerts is standard\*\*



The tool must be in contact with the ground in order to activate the quick hitch lock. \*\*\*

## Light Module





The rear axle lock also keeps the front axle in position, thus minimising the risk of accidents caused by swinging tools that are only hooked to the front axle.

The hook is safety classified in compliance with EN ISO 12100-1/A1:2009 and EN ISO 12100-2/A1:2009

engcon | EC-Oil™

Double electronic sensors ensure contact with front and rear pins.

The unique shape of the lock bolt retains the tool in the quick hitch even if other safety functions should fail.

A check valve prevents the locking cylinder from returning even if a pressure drop occurs.

Powerful springs retain locking capability even under pressure loss.

engcon hitches are fitted as standard with EC-Oil™, engcon's automatic hydraulic connector system.

The combination of engcon's safe quick hitch and the warning light & sound module alerts both visually and audibly unless both bucket axles are in their correct locked positions.

The module is installed on the left side of the excavator dipper and its cabling is integrated into control system cabling.

If a control system other than the DC2 is used, a separate cable is run for the warning module into the excavator cab.

Order the full system with slew limitation and ground contact for releasing tools in consultation with the machine supplier concerned.

# Standardised locking system

Standardised operation of the machine hitch and tiltrotator quick hitch improves safety

Today there are around 20 major excavator manufacturers, all of whom have well-functioning systems for operating the machine and quick hitches. However, the operation and location of the lock buttons for these hitches differ between each machine manufacturer and model.

Consequently, in situations where the excavator operator uses different machine types, there is a clear risk of incorrect operation. It's comparable to having different positions for the brake and accelerator pedals depending on the make of a car.

Here at engcon, we're taking yet another step forward in our safety efforts. Our goal is to standardise and ensure safe operation of all quick hitches, for all excavators. With every purchase of an engcon machine hitch, tiltrotator and proportional control system, we include our standardised locking system for safe operation of the tiltrotator's quick hitch. An optional extra also enables machine hitch operation from the same panel.

engcon has developed a standardised locking system that minimises the risk of activating the wrong button or function. The locking system is compatible with most makes of excavators, tiltrotators and quick hitches on the market. The system consists of a control panel with a switch to activate the excavator's machine hitch and another to activate the tiltrotator's quick hitch. All functions are brought together in a panel that is always located in the same position in the operator's cab, where it is easily recognisable regardless of the excavator's make or model. An operator switching from one excavator to another must be able to easily recognise the controls and thus minimise the risk of dangerous mistakes.

When using the engcon locking system, the selected quick hitch – regardless of make or model – gains an additional unique safety function that requires ground



pressure on the bucket to release it. This means we've made it almost impossible to disconnect the bucket when it is in mid-air. Thus the risk of accidents caused by falling buckets is minimised.

” It's comparable to having different positions for the brake and accelerator pedals depending on the make of a car.

Together with the engcon locking system and quick hitch, safety is further increased by means of audible and visual warnings. Unless both bucket axles are correctly engaged, the system uses sound and light alerts while also activating the slew lock and boom lock functions.

For the engcon quick hitch and locking system combination, engcon offers a system for operating the quick hitch. This means the operator always knows what is happening and when it happens.





## Standardised system for hitch control on the machine and the tiltrotator

- + engcon's intelligent, safe locking system comes as standard on engcon tiltrotators and optional extras for the machine hitch, which can then be operated from the same panel
- + Standardises operation – regardless of excavator make and model
- + Lock panel with auto-guidance, where the right button lights up
- + Meets applicable safety standards for machine hitches and quick hitches
- + Ground pressure sensor for greater safety when switching tools – not possible to open the bucket lock with the bucket in mid-air
- + Audiovisual alarm system that alerts with sound and light when coupling
- + If the optional extra of operating the machine hitch from the same panel is purchased, modifications are necessary to the machine manufacturer's machine hitch locking function

Read more on our website: [www.engcon.com](http://www.engcon.com)

# Automatic quick hitch

## S40–S80

**Quick hitches with a new level of safety!**  
**For all excavators in the 4-40 tonne weight classes.**

### Advantages

- » EC-Oil automatic quick hitch system connects the tiltrotator and hydraulic tools without the operator having to leave the cab.\*
- » Hydraulic locking with fourfold safety:
  1. Electronic sensors detect when both axles are in contact
  2. A check valve prevents the hydraulic cylinder from opening in the event of a hose rupture or pressure-drop
  3. Powerful exterior springs keep the hitch locked even if the electronics and hydraulics fail.
  4. The unique design of the lock bolt provides additional safety in that the bucket axle bottoms against the hitch side plates, preventing it from dropping out of position even if all three of the preceding steps should fail.
- » The tool can only be removed when it is resting on the ground at a given pressure (with the engcon locking system). This minimises the risk of dropped buckets.
- » Front and rear locks minimise the risk of accidents caused by swinging tools
- » Supplied as standard with external audible and visible warning signals to alert the surrounding area
- » Wedge-shaped hooks to minimise play between the machine hitch and tool and between the quick hitch and tool



- » Probably the only quick hitch where the hooks face the direction of excavation thus distributing the forces across the entire hitch
- » Longer engagement hooks (shark jaws) to make picking up tools safer and easier
- » Manufactured from high-strength steel
- » Fits all excavators in the specified weight class independent of control system
- » The hook is safety classified in compliance with EN ISO 12100-1/A1:2009 and EN ISO 12100-2/A1:2009

\* Read more on page 6



Read more on  
page 6

# Other quick hitches

## S30, S40

**For all excavators in the 1,5-4 tonne weight classes**

- » Can be supplied with hydraulic or mechanical locking
- » Hydraulic locking for speedy attachment and tool changes straight from the cab
- » Play-free connection
- » Changeable for deep and shallow excavation (S30)
- » Robust, reliable and affordable
- » Low installation height
- » Low weight
- » Welded, high-strength steel





## Attachment brackets for EC-Oil

GS40-ECO, GS45-ECO, GS50-ECO,  
GS60-ECO, GS70-ECO, GS80-ECO

**Adapt your hydraulic tools for EC-Oil.**  
**Suitable for all excavators in the 4-40 tonne weight classes.**

- » Bucket/attachment bracket suitable for EC-Oil™ connectors
- » Standard bolt pattern that fits engcon hydraulic tools or weld-on bracket
- » Possible to equip with one or two EC-Oil blocks
- » Easy to adapt to all types of hydraulic tools
- » Robust, reliable and affordable
- » Engineered in high-strength steel



Bolt-on bracket with  
EC-Oil block



Weld-on bracket with  
EC-Oil block

## EC-Oil™

## Attachment brackets

GS30–GS80

**For all excavators in the 1,5-33 tonne weight classes**

- » Easy-to-modify buckets for engcon hitches
- » Robust, reliable and affordable
- » Welded, high-strength steel



**Adapt to fit your  
existing tools**

**EC-Oil bracket**

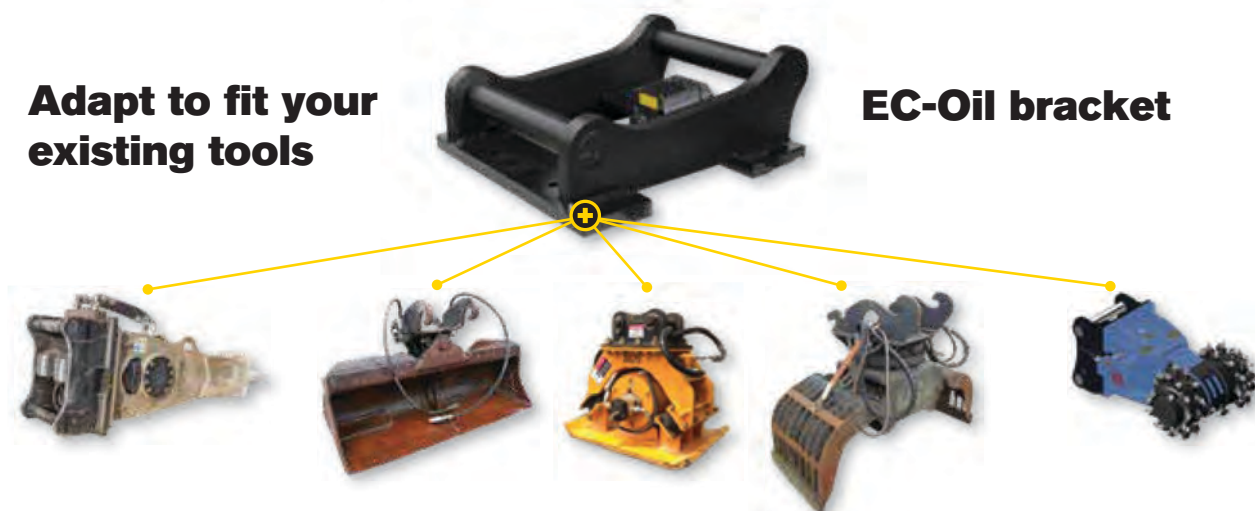

# Detachable Gripper

GRD40, GRD45, GRD60, GRD70

**engcon's detachable gripper cassette is also retrofittable. For excavators in the 4-30 tonne weight classes, quick hitch S40-70.**

The gripper cassette simply hooks onto the quick hitch, whereupon the cassette is locked on and the hydraulics connected in a single operation – a procedure that takes less than a minute. The gripper is angled 15 degrees to the tiltrotator, which extends gripper reach.



### Quick locking

The gripper cassette is locked and the hydraulics connected in a single movement with a simple procedure using a 32 mm box end wrench. This means connection and disconnection take less than a minute.







## Detachable rotating brush

SWD40-SWD60

**engcon's detachable rotating brush is also retrofittable. For excavators in the 4-19 tonne weight classes, quick hitch S40-60.**

As with the gripper cassette, the rotating brush can be retrofitted on the quick hitch by hooking onto the hitch's two attachment hooks. The rotating brush is then locked and connected to the hydraulics in a single quick and easy operation. The rotating brush is driven by a powerful hydraulic motor and is folded up or down with a hydraulic cylinder.

The engcon rotating brush is flexible and its width can be adjusted to suit the job in hand, from cable sweeping to clearing large areas. Reduces the need for manual labour and makes work safer. The rotating brush is available in several widths and is suitable for the new engcon quick hitch.







## Integrated gripper

### GR20R2

#### Integrated gripper for EC214, EC219 and EC226\*

The new integrated gripper is specially developed for the tough environments that gripper are exposed to on the railway, where a gripper will often be used to pull and lift heavy rails with excavators.

#### Advantages:

- » Robust construction designed for heavy and demanding use such as in the railway industry
- » Angled up to 42 degrees
- » Large gripper width – 820 mm
- » Protected cylinders

\* Standard hitch combinations: S45-S70.







# Stone and sorting grapples

SG03, SG06, SG12, SG19, SG26, SG33

**For all excavators in the 1.5-33 tonne weight classes**

engcon's stone & sorting grapples in the SG series are suitable for everything from sorting to light demolition works where a powerful grapple is needed. When used in combination with the engcon tiltrotator, it provides the accessibility you need, and the EC-Oil automatic oil connection system is installed as standard\*

## The benefits of SG grapples

- » EC-Oil automatic quick hitch system connects hydraulics without the operator having to leave the cab
- » The grapple's claws are fitted with reversible wear bars
- » The load valve and pressure accumulator maintain gripping force for extended periods to ensure safe lifting
- » Complies with European safety standards
- » Expander bushings in major joints
- » Bolt-on bracket/attachment point makes switching brackets easy

## Accessories:

- » Tooth kit for better grip
- » Closed sides to convert the grapple into a clamshell bucket

\* Applies to grapples with S40-S80 attachment points.



With teeth  
(accessory)



With closed sides  
(accessory)



Read more on  
page 6

# Timber/combi gripper

## TG25HD–TG55HD

**For all excavators in the 4-33 tonne weight classes**

Used with a Tiltrotator, the engcon combi gripper is the ultimate tool for handling round timber and pipes, and light sorting jobs. The gripper are reinforced with high-strength steel wear bars with 400 Brinell hardness and can be adapted to fit a large number of attachment points.

### Advantages:

- » EC-Oil automatic quick hitch system connects hydraulics without the operator having to leave the cab
- » Gripper arms in high-strength steel for increased service life
- » Gripper tips have wear bars; 400 Brinell hardness for best durability
- » A check valve built into the hydraulic cylinder and an accumulator installed directly on the cylinder without hoses, keep the load safe and secure should any pressure drop occur
- » Expander bolts in joints prevent unnecessary play
- » Bolt-on bracket/attachment point makes switching brackets easy
- » Bolt-on bracket/attachment point means dealers need keep fewer timber/combi grapples of the same size in stock



Read more on  
page 6

# Rotating brush

## SR800–SR2000

**For excavators in the 6-33 tonne weight classes**

Used with a tiltrotator, engcon rotating brushes extend an excavator's abilities and open up previously undreamed-of possibilities in a wide range of specialist areas. Regardless of whether you'll be sweeping snow, sand, gravel or soil, this will soon become a favourite tool that you just cannot live without. In the winter, you can use it in areas such as pedestrian crossings, walkways, railway points, etc. where snow normally has to be cleared manually.

In the summer, the brush can be used for sweeping road sand and gravel, brushing grassed areas, foundations, rocks and more. The only limit is your imagination. A hydraulic motor provides the power, and a geared chain drive enables brush rotation speed to be adjusted.



The open design allows unsurpassed service-friendly access, and the standard polypropylene brushes can be replaced quickly and easily. Easily adaptable for the EC-Oil automatic oil connector system and can thus be connected without the operator having to leave the cab. The EC-Oil automatic oil connection system is the engcon standard. Thus the rotating brush can be connected without the operator having to leave the cab. Bolt-on bracket/attachment point makes switching brackets easy whenever necessary and reduces the need for dealers to keep multiple rotating brushes of the same size in stock.



Read more on  
page 6



# Pallet fork

GH1000, GH1200,  
GHH1200, GHH1200L

**For all excavators in the 4-33 tonne weight classes.**

Hydraulic and mechanical pallet forks for all excavators. – A robust and well-conceived design for best through-visibility. Tempered tines assure long service life.

**NOTE!** Always check which safety instructions apply for use of a pallet fork on the type of machine being used. When using the pallet forks together with a tiltrotator, a load-holding valve must be fitted to the tiltrotator. engcon tiltrotators are fitted with load holding valves on the tilt cylinders as standard.

- » EC-Oil automatic quick hitch system connects hydraulics without the operator having to leave the cab
- » Hydraulic pallet forks are operated from the cab
- » Mechanical pallet forks are held in position with robust catches, and fork positions are adjusted manually
- » Forged tines for greater durability and service life

**GH** = Mechanical fork widening,  
**GHH** = Hydraulic fork widening  
**GHH1200L** = Hydraulic fork widening,  
Light version for lighter machines.

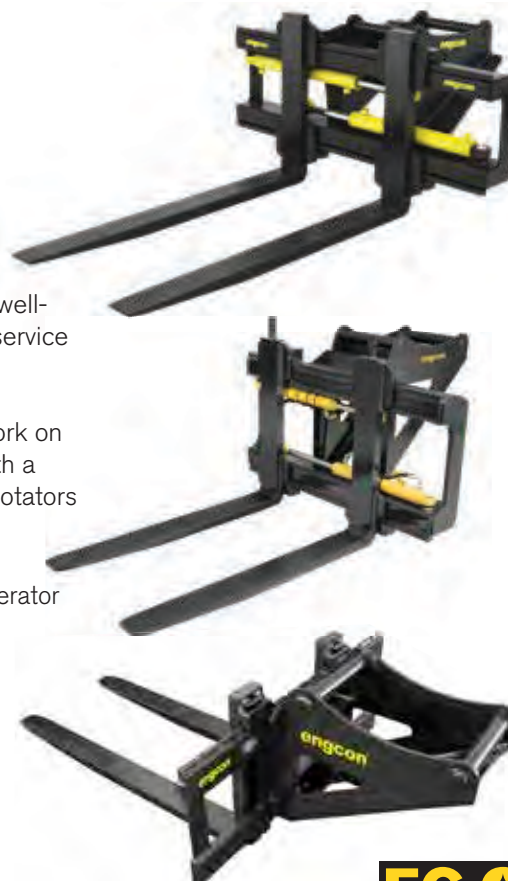

Read more on  
page 6

# Lightweight pallet fork

GH1000L, GHH1000L

**For all excavators in the 2-6 tonne weight classes.**

The lightweight pallet fork are available in two versions, one hydraulic and the other mechanical, able to handle loads of 2 tonnes TP500, meaning it is classified for a 2 tonne load 500 mm from the rear of the tines, whose standard length is 800 mm.

The hydraulic version is designed for engcon's EC-Oil automatic quick hitch system allowing the operator to connect the pallet fork and its hydraulics automatically without climbing out of the cab. The hydraulic pallet fork with EC-Oil is a perfect fit for the new EC206, which will be fitted with our automatic quick hitch under the tiltrotator this year.



- » Low weight suitable for excavators up to 6 tonnes
- » EC-Oil automatic quick hitch system connects hydraulics without the operator having to leave the cab
- » Hydraulic pallet forks are operated from the cab
- » Mechanical pallet fork tines are held in position with robust catches, and tine positions are adjusted manually
- » Forged tines for greater durability and service life



Read more on  
page 6

# Compactor

PP350, PP950

## For all excavators in the 6-33 tonne weight classes

- » The EC-Oil automatic quick hitch system connects hydraulics
- » Compaction plate in hard-wearing steel
- » Side plating for grading mass fill
- » Open short ends make cleaning the plate topside easy
- » Joined using rubber elements of adequate stiffness for grading and positioned for effective vibration damping
- » The vibration unit and hydraulic parts are well-protected inside the side plates
- » Can be fitted with optional attachment point
- » Complete with flow control valve
- » Complies with European safety standards
- » Tandem-connected weights
- » Bolt-on bracket/attachment point makes switching brackets easy
- » Bolt-on bracket/attachment point reduces the need for dealers to keep multiple compactors of the same size in stock



**EC-Oil**  
STANDARD

Read more on  
page 6

# Compactor

PP3200

## For all excavators in the 6-12 tonne weight classes

- » The EC-Oil automatic quick hitch system connects hydraulics
- » Low flow requirement (35 litres) allows the PP3200 to be run directly off the extra connections on the tiltrotator
- » Variable working width
- » Specially adapted pack cushions
- » Compaction plate in hard-wearing steel
- » Side plating for grading mass fill
- » Open short ends make cleaning the plate topside easy
- » Joined using rubber elements of adequate stiffness for grading and positioned for effective vibration damping
- » The vibration unit and hydraulic parts are well-protected inside the side plates
- » Can be fitted with optional attachment point
- » Complies with European safety standards
- » Supplied as standard excluding attachment point and machine hoses
- » Bolt-on bracket/attachment point makes switching brackets easy
- » Bolt-on bracket/attachment point reduces the need for dealers to keep multiple compactors of the same size in stock



### Accessory:

Extension plates, trenching blade, specially adapted compactor pads for e.g. packing in sheet-pilings.

**EC-Oil**  
STANDARD

Read more on  
page 6





# Compactor

## PC6000

### For all excavators in the 12–26 tonne weight classes

- » EC-Oil automatic quick hitch system comes as standard, which means the operator can connect the ground compactor and its hydraulics without having to leave the cab.
- » Its low flow requirements mean the PC6000 can be driven using the tiltrotator's extra hydraulics.
- » Better access means it is easier to perform more types of jobs when used together with a tiltrotator.
- » Having no personnel present in the excavation minimises the risk of injury, which can occur if vibrations cause the soil to collapse.
- » No more lifting hand-operated ground compactors that risk being dropped or can collide with personnel or objects in the surroundings.
- » No oil drain line means fewer hoses to chafe and burst.
- » Bolt-on bracket makes it easy to switch hitch systems.



Read more on  
page 6



# Grading beam

## GRB1250–GRB3000

With engcon's grading beam, you can grade large areas quickly and efficiently.

The grading beam is a smart, flexible solution as it has a bolt-on bracket/attachment point with the same bolt pattern as other tools (e.g. stone and sorting grapple, compactors and rotating brushes) from engcon. The side beams can be extended with bolt-on 500 mm extensions. This means that our dealers do not need to carry several different grading beam versions since a single model covers various configurations. End-users and contractors can also get by with a single beam for several machines if they do not need to use more than one at a time.

What's more, engcon's grading beam has cutters on the leading edge and wear bars under the entire structure. This means a long life, making the grading beam even more profitable. The journalled compactor roller can be raised and lowered to achieve the best setting for your particular needs. engcon's grading beam comes in five different widths to cover almost any need for efficient grading.



### Advantages

- » More efficient surface grading means greater profitability
- » Robust design
- » Bolt-on bracket/attachment point
- » Cutters at the leading edge
- » Wear bars under the entire structure
- » Extendable side beams
- » Journalled compactor roller
- » Compactor roller can be raised and lowered
- » Bolt-on bracket/attachment point makes switching brackets easy
- » Bolt-on bracket/attachment point reduces the need for dealers to keep multiple grading beams of the same size in stock

**NOTE.** the engcon grading beam is even more efficient when used with a tiltrotator, but it is then important to consider the loads the tiltrotator will be subjected to. Use the grading beam for its intended purpose – grading. Large quantities of material can be moved quickly and efficiently with engcon's range of buckets.

# Cable bucket

## CB01–CB29

### For all excavators in the 1.5-33 tonne weight classes

engcon's cable bucket – developed for precision excavation with minimal width for e.g. cables or other utilities requiring narrow trenches. Its deep profile means better accessibility beneath intersecting cables and pipes and also allows deep trenching without any need for the tiltrotator to go below surface level.

**engcon's cable buckets are available in two models – Standard and tapered (C), Standard** is of conventional type with straight side plates for excavating ditches with vertical sides. **The tapered** model has a narrower blade than the standard cable bucket but with the same width top, producing a narrower trench bottom with slightly sloping sides.

engcon's cable buckets are made from high-quality steel. As with other engcon buckets, the cutters and other exposed wear surfaces have a hardness of 500 Brinell.

**A factory-installed tooth kit is available as an optional extra.**



Standard



Conical



Tooth kit, type Cat



Blade teeth provide smooth ditch bottoms



# Deep-digging bucket

DB01–DB32

**For all excavators in the 1.5-33 tonne weight classes**

engcon deep-digging bucket – Robust design for tough jobs. A favourite for anyone needing to excavate and dig in difficult conditions where fast penetration and easy filling are priorities, e.g. in trenching and other soil removal requiring capacity.

On request, the bucket can be fitted with the following accessories:

- » Tooth kit\*
- » Tooth cover
- » Blade teeth

*\* When selecting a tooth kit, engcon buckets are fitted with the Cat J system as standard equipment. For other tooth systems, check availability with engcon*



# Sorting bucket

SB02–SB29

**For all excavators in the 1.5-33 tonne weight classes**

The engcon series of sorting buckets are designed for quick, simple sorting. Sorting buckets require no hydraulics; they are made from high quality steel. Cutters and bars have a hardness of 500 Brinell – the same high quality as every other engcon bucket. All for greater efficiency and a long service life.



# Sorting bucket

SKB02–SKB29

**For all excavators in the 1.5-33 tonne weight classes**

The engcon sorting bucket is designed to more easily get beneath the material intended for sorting. It has a slightly narrower shape than the engcon SP sorting bucket and its long base and low side panels make it easier to get beneath e.g. asphalt or other material intended for sorting. The base ribs run along the length of the bucket, allowing material to slide easily in and out.

The SKB sorting bucket requires no hydraulics and is thus ideal for simple sorting work where e.g. finer material is required for backfill or some other use. The cutters, lower side plates and ribs are made of high-strength wear bar with a hardness of up to 500 Brinell, thus guaranteeing high efficiency and long service life.



# Grading bucket

GB01–GB29

For all excavators in the 1.5-33 tonne weight classes

engcon grading bucket – Optimised together with experienced contractors for use together with the tiltrotator. -Chamfered corners from the base all the way to the top plate to avoid striking house walls and other objects that are susceptible to damage from the rotating bucket. Tapered shape for easier filling and an adapted 16 degree-angle between the attachment point and base for easier bucket rotation without losing material.



## engcon grading bucket features

- 1 Chamfered corners to avoid collisions
- 2 Bucket top plate angle adapted for tiltrotator
- 3 Hardox reinforcements on other wear surfaces
- 4 Tapered for easier filling and better release
- 5 Wear bar and cutter – hardness 500 Brinell

# Water & sewerage bucket

TB07–TB23

For all excavators in the 8-23 tonne weight classes

engcon water/sewerage bucket – Specially designed for excavating water and sewerage trenches and other utilities tasks that call for a deep-digging bucket with a slightly longer base and a cutter without teeth. Like other buckets in the engcon range, the water/sewerage bucket is reinforced with Hardox at the most exposed points.



# New bucket range for detachable grippers

A new gripper-compatible bucket series was developed in parallel with the detachable gripper where the rear bucket panel has a notch that aligns with the gripper's counterhold. In this way, the bucket acts as an extended support for grabbed objects like posts or pipes. Available as standard in 2023.







## Asphalt cutters

TC03–TC33

**For all excavators in the 1.5-33 tonne weight classes**

engcon asphalt cutter – the engcon asphalt cutter allows you to make first-rate cuts and avoid expensive costs with asphalt dug up unnecessarily. Can also be used for first-rate cuts on grass surfaces and other locations where precision is called for.



## Ripper

R06–R33

**For all excavators in the 1.5-33 tonne weight classes**

engcon ripper – With the engcon ripper you'll find no problem in penetrating frozen and hard ground. The ripper is optimised for the best ripping ability and breakout force in hard material.









## ENGCON JOYSTICKS

# Enjoy your work with good ergonomics and functionality



engcon joysticks for excavators combine comfort and efficiency with functionality. The joystick was developed to comply with requirements for increased safety and more control functions.

engcon joysticks were designed in collaboration with contractors and a company specialised in industrial design. Each one can be fitted with three rollers and seven buttons, providing twice the number of buttons and rollers with two levers. The operator is therefore able to work at maximum efficiency while also sparing the body strenuous

movements and stressful working positions.

The joystick has an integrated hand support for the wrist to rest on without affecting the excavator movements. The hand rest is flexible and can be adjusted to suit different hand sizes.

The engcon joystick is not only ergonomic, but also provides the operator with new capabilities on the job. The joystick rollers are designed for the thumb, index and middle fingers – a unanimous demand by all concerned. In this way the operator can combine six rollers simultaneously when necessary.

## ENGCON CONTROL SYSTEM

# Proportional control system with remote support

Our proportional control system meets the high standards demanded of all components such as hydraulics, electronics and software. Used together with engcon tiltrotators and quick hitches, the control system creates a safer work environment. The engcon control system provides the ability for e.g. track or wheel control and boom slew. A smartphone app allows remote support as a complement to PC and USB cable connection. The product meets the ISO 13849-1 safety standard.

## Advantages:

- » Proportional / infinitely variable tiltrotator and tool control
- » Complies with international machine safety standard SS-EN ISO 13849-1
- » Speedy installation with all connections made using socket connectors
- » The MicroConf PC-programme enables you to make fine adjustments and instantly follows the effect of changes made when the tiltrotator is in use
- » The system makes a back-up of all the settings from the cab module to the aggregate module
- » Display for alarm and for making system settings
- » Double feeder function
- » Robust design increases operational safety
- » Option of track control, wheel control and boom slew
- » Settings via Bluetooth and smartphone as an alternative to PC and USB cables
- » Control with up to six rollers
- » Suitable for most machines on the market
- » Possible to create three individual operator profiles
- » Multiple CAN integrations for excavator manufacturers for ease of installation and a seamless experience

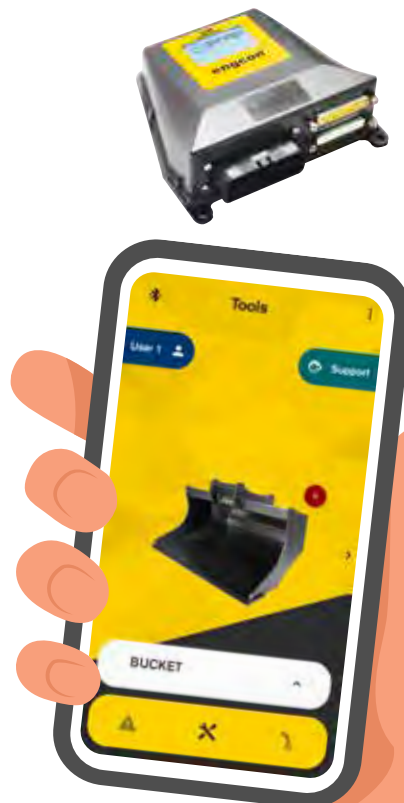
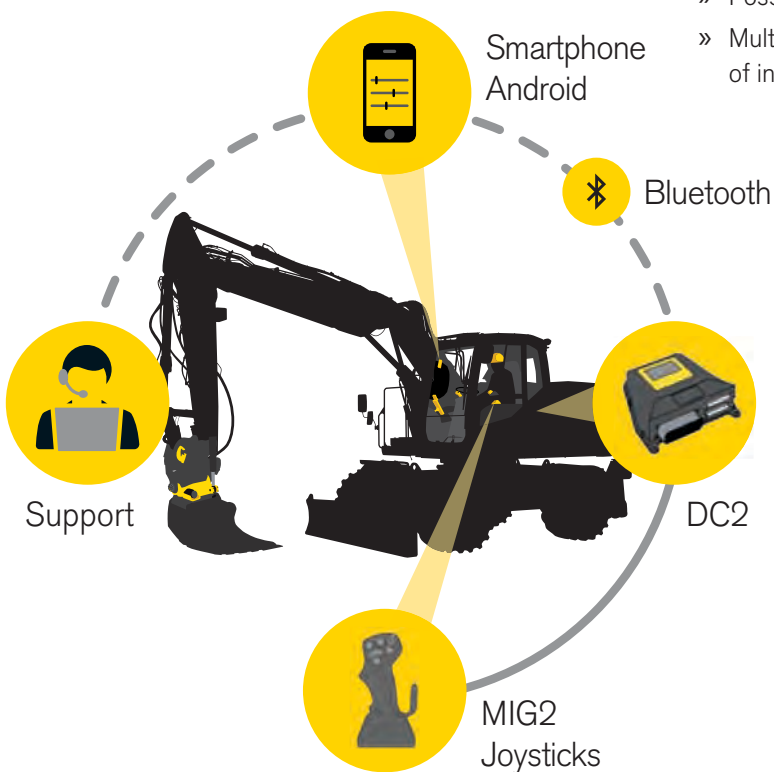





# engcon Positioning System

During the past year, engcon has standardised ePS sensors on EC214 tiltrotators and higher. The advantage is that rotation and the tilt angle can be obtained for integrated, aftermarket installed machine control systems.\* Because the sensors are standard, it's also easier to retrofit ePS. Also available when the ePS option is selected for EC206 and EC209.

## Conditions

The technology is based on signals from the system to the excavator guidance system used on the customer's excavator.

engcon supplies the rotation sensor and tilt sensor.

The auto-tilt and auto-rotation functions are available for the engcon Positioning System in combination with certain makes of excavator guidance systems and excavator marques. Contact your excavator guidance system supplier for further information.

## Advantages

Together with the selected excavator guidance system, the engcon Positioning System reduces the need for a conventional set-up, and the operator can view the precise excavation area on the machine control system display in the cab. This control, which ensures the exact right amount of material is excavated, provides many advantages:

- » Reduced job time
- » Reduced fuel consumption
- » Reduced wear on machines and tools
- » Saves time for other units, such as trucks/dumpers
- » Adapted to the engcon proportional system but also possible to install on other control systems
- » Fully independent of control system make or model via own cabling

\* This through our machine control rated sensors

# Technical data

Please direct any questions to your local engcon office.

Technical data may vary. We reserve the right to make changes without prior notice.

## Tiltrotator

Specifications	EC02	EC204	EC206	EC209	EC214	EC219	EC226	EC233
Width A: (mm)*	180	267	286	277	320	396	426	501
Width B: (mm)*	155	161	220	250	285	315	340	385
Width C: (mm)*	160	169	219	273	303	310	340	385
Total length D: (mm)*	435	463	500	561	665	737	760	878
Build height E: (mm)*	from 245	from 310	from 380	from 425	from 457	from 480	from 500	from 673
Weight: (kg)*	77	116	170	287	385	447	632	812
Tilt:	2x40°	2x45°	2x45°	2x45°	2x45°	2x45°	2x45°	2x45°
Rec. hydraulic flow DC2/SS10 (l/min):	25	30	40	60	80	120	120	120
Rec. hydraulic flow SS9 tilt/rotation: (l/min):	7/20	10/25	15/30	35/40	35/50	65/70	70/70	70/70
Max hydraulic pressure: (MPa)	22	22	22	22	22	22	22	25
Standard hitches:	S30	S40	S40, S45	S45	S45, S60	S60	S70	S70, S80
Max bucket width rec engcon: (mm)	900	1 000	1 200	1 300	1 600	1 700	2 000	2 200
Max breakout torque: (kNm)	20	28	45	74	126	186	270	340
Base machine weight: (t)	1,5–2,5	2–4	4–6	6–9	9–14	14–19	19–26	24–33

\*Standard attachment

## Tiltrotator storage and transport stand

Specifications	
Length: (mm)	1200
Width: (mm)	800
Height without attachment point: (mm)	150
Weight without attachment point: (kg)	82

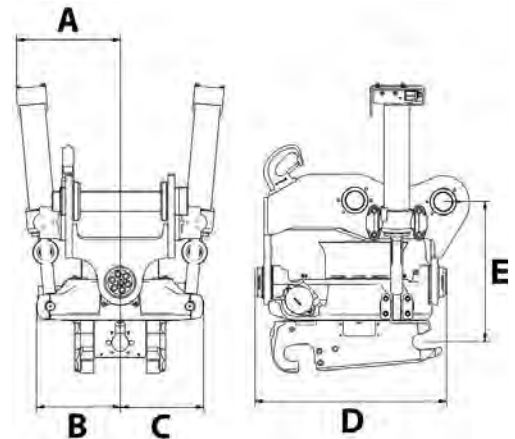

## Automatic quick hitch

Specifications	S40	S45	S60	S70	S80
Axle diameter A: (mm)	Ø40	Ø45	Ø60	Ø70	Ø80
Width B: (mm)	200	290	340	450	590
Length C: (mm)	300	430	480	600	670
Build height D: (mm)	135	140	170	190	270
Weight*: (kg)	50	100	180	290	370
Recommended hydraulic pressure open/closed (MPa)	21-25	21-25	21-25	21-25	21-25
Max hydraulic pressure: (MPa)	35	35	35	35	35
Base machine weight: (t)	2-6	6-11	12-19	20-30	27-40

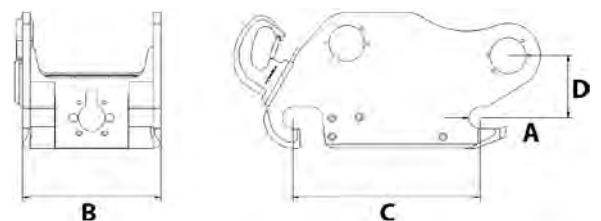

\*Depending on attachment point



## Attachment brackets

Specifications	GS30/180	GS40/200	GS45	GS60	GS70	GS80
Axle diameter A: (mm)	Ø30	Ø40	Ø45	Ø60	Ø70	Ø80
Width B: (mm)	180	200	290	340	450	590
Length C: (mm)	230	300	430	480	600	670
Suitable for engcon RF:	S30	S40	S45	S60	S70	S80

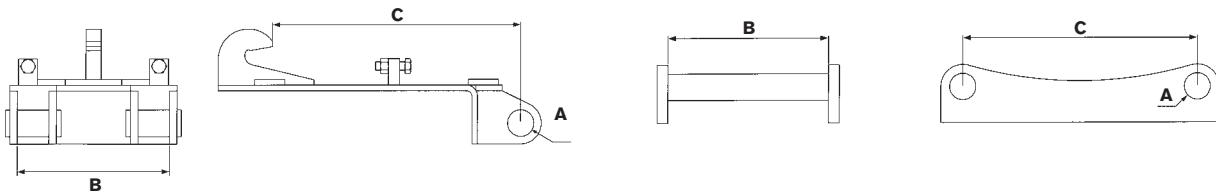

## Other quick hitches

Specifications	S30	S40
Axle diameter: (mm)	Ø30	Ø40
Width: (mm)	180	200
Length: (mm)	230	300
Build height: (mm)*	110	110
Weight: (kg)*	15	25
Recommended hydraulic pressure open/closed	21/3-6	21/3-6
Max hydraulic pressure: (MPa)	22	22
Base machine weight: (t)	1-2	2-6

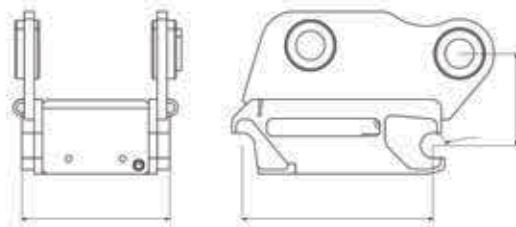

\*Depending on attachment point

## Detachable rotating brush

Specifications	SWD40	SWD45	SWD60
Length, cassette A: (mm)	451	586	665
Length, arm B: (mm)*	843	875	975
Width, cassette C: (mm)	314	362	423
Width, guard D: (mm)**	340, 1 200	450, 1 400	450, 1 600
Height, guard E: (mm)	660	660	660
Max total length A+F (mm)**	1 550	1 710	1 998
Diameter, sweeper brush G: (mm)***	600, 700	600, 700	600, 700, 915
Width, sweeper brush H: (mm)	340, 1 200	420, 1 400	420, 1 600
Maximum weight: (kg)**	127	186	210
Oil flow min/max: (l/min)	20/50	20/60	20/60
Fits quick hitch:	S40	S45	S60

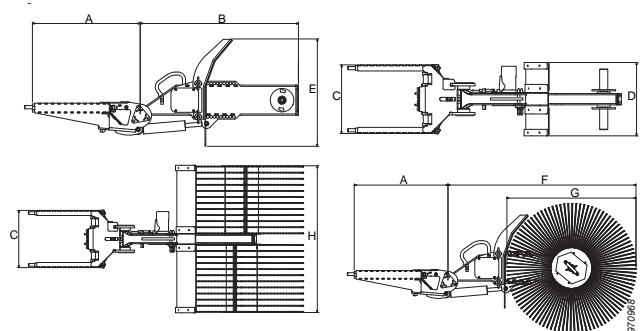

\* In the standard version

\*\* Depends on sweeper brush

\*\*\* 915 mm can only be used with long arm (975 mm)

### Detachable Gripper

Specifications	GRD40	GRD45	GRD60	GRD70
Gripper width A: (mm)	430	610	820	950
Width B: (mm)	220	270	355	410
Length C: (mm)	540	720	870	900
Clamping force (tip to tip) at 21 Mpa: (kg)	1200	1 500	2 200	2 200
Max load: (kg)	1000	1 500	2 000	2 000
Weight: (kg)*	45	99	153	169
Max hydraulic pressure: (MPa)	22	22	22	22
Fits quick hitch:	S40	S45	S60	S70

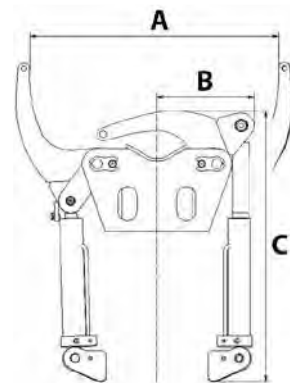

### Integrated gripper (railway use)

Specifications	GR20R2
Widest gripper width A: (mm)	820
Width B: (mm)	380
Length: (mm)	Depending on the hitch
Weight: (kg)	140
Clamping force at 21 Mpa: (kg)	1750
Angled at 35-42° depending on the bracket	
Detachable	
Protected cylinders	

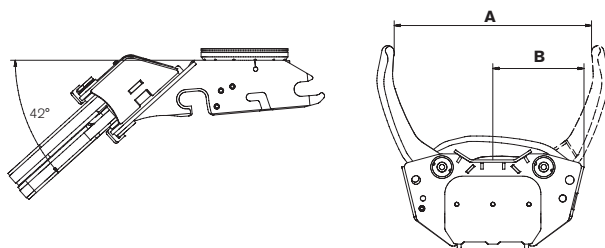

Note! GR20R2 cannot be combined with all quick hitches on the market. Contact engcon for further information.

### Compactor

Specifications	PP350	PP950	PP3200
Compaction force: (kg)	3 500	9 500	3 200
Compaction area: (m <sup>2</sup> )	0,42	0,90	0,4-0,56
Max hydraulic pressure: (MPa)	22	22	22
Recommended hydraulic flow: (l/min)	68	120	34
Max recommended return line pressure: (MPa)	1	1	2,5
Weight excl. attachment point: (kg)	390	900	470
Length A: (mm)	890	1 270	1 000
Width B: (mm)	620	900	500-700
Height C: (mm)	450	600	590

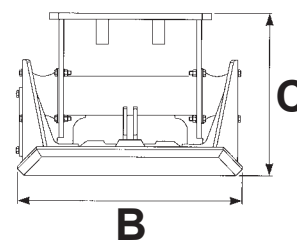
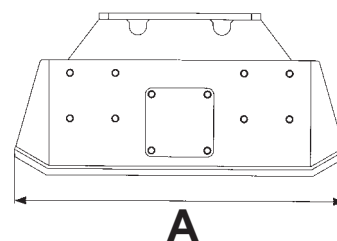

Specifications	PC6000
Width (mm)	720
Height excluding attachment point (mm)	508
Length (mm)	1065
Weight excluding attachment point (kg)	560
Recommended hydraulic flow from [l/min]:	55
Compaction area [m <sup>2</sup> ]:	0,44
Compaction force [kN]:	60
Max hydraulic pressure [bar]:	22
Max recommended return line pressure [bar]:	20



## Timber/combi gripper

Specifications	TG25HD	TG28HD	TG42HD	TG55HD
Max grapple width B: (mm)	1 450	1 540	1 900	2 510
Max load: (t)	3	5	6	10
Height, fully open A: (mm)	759	889	1 039	1 146
Height, fully closed D: (mm)	526	659	751	946
Width E: (mm)	460	595	677	802
Gripping force, tip to tip, at 21 Mpa (kN)	6,8	12,42	20,4	31,86
Max hydraulic pressure: (MPa)	22	22	22	22
Weight: (kg)	195	360	595	1 070
Grapple area C: (m <sup>2</sup> )	0,25	0,28	0,42	0,55
Recommended machine weight: (t)	4-9	9-14	12-19	19-33

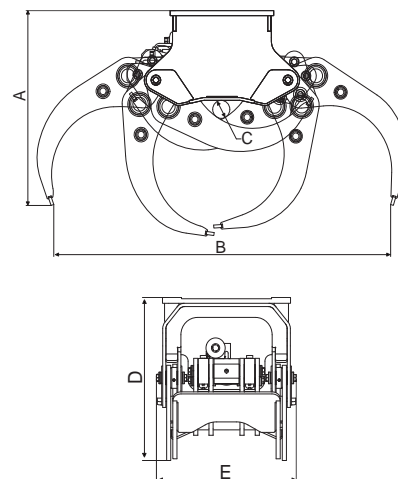

## Pallet fork

Specifications	GH1000	GH1200
Width: (mm)	1000	1,200
Fork: (mm)	100x40x1 200	125x45x1 200
Weight: (kg)*	180	360
TP500 (t)	2,9	4,7

Specifications	GHH1200	GHH1200L	GHH1200L
Width: (mm)	1,200	1,200	1,200
Fork: (mm)	125x45x1 200	100x40x1 200	125x45x1 200
Weight: (kg)*	400	260	313
TP500 (t)	4,7	2,9	4,7

\* Depending on hitch

## Lightweight pallet fork

Mechanical pallet fork	GH1000L
Recommended machine weight (t)	2-6
Standard hitch	S40
Estimated weight (kg)	141
Dimension (mm)	80x40x800
Width (mm)	1000
Tine length (mm)	800
TP500 (t)	2

Hydraulic pallet fork	GHH1000L
Recommended machine weight (t)	2-6
Standard hitch	S40 with EC-Oil
Estimated weight (kg)	151
Dimension (mm)	80x40x800
Width (mm)	1000
Tine length (mm)	800 (1200 also available)
TP500 (t)	2

## Stone and sorting grapple

Specifications	SG03	SG06	SG12	SG19	SG26	SG33
Max grapple width A: (mm)	750	1 110	1 660	1 790	1 990	2 575
Min grapple width A: (mm)	0	0	0	0	0	0
Cutting width B: (mm)	400	505	715	860	860	1 170
Jaw length C: (mm)	490	460	680	790	870	1 180
Height D: (mm)	550	580	790	960	1 070	1 360
Volume, with side plates: (l)	42	83	220	336	420	930
Gripping force: (kN)	5,7	8,7	15	19	25	45
Max hydraulic pressure: (MPa)	22	22	22	22	22	22
Weight: (kg)*	108	180	425	646	755	1 400
Grapple area: (m <sup>2</sup> )	0,12	0,17	0,34	0,42	0,52	0,85
Rec. machine weight (t)	1,5-3	3-6	6-12	12-19	18-26	24-33
Recommended tiltrotator:	EC02	EC204 EC206	EC209 EC214	EC214 EC219	EC219 EC226	EC226 EC233

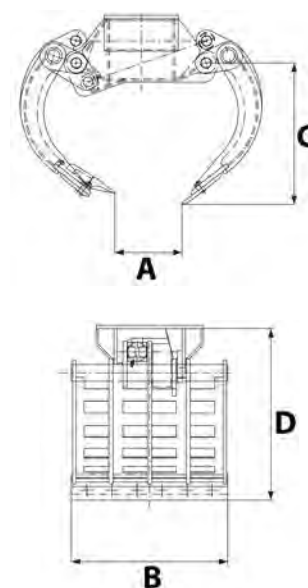

\* Depending on attachment point

## Rotating brush

Specifications	SR800	SR1300	SR1600	SR1800	SR2000
Min hydraulic flow: (l/min)	20	20	20	20	20
Max hydraulic flow: (l/min)	60	60	60	60	60
Weight excl attachment point: (kg)	210	240	260	275	290
Width A: (mm)	800	1 300	1 600	1 800	2 000
Height B: (mm)	1 257	1 257	1 257	1 257	1 257
Length C: (mm)	1 060	1 060	1 060	1 060	1 060

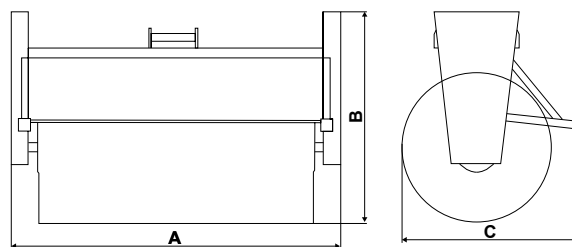

## Grading beam

Specifications	GRB1250	GRB1500	GRB2000	GRB2500	GRB3000
Width (mm):	1 250	1 500	2 000	2 500	3 000
Depth (without extensions) (mm):	962	1 000	1 000	1 000	1 000
Height (without attachment point) (mm):	275	387	387	387	387
Diameter (roller) (mm):	178	245	245	245	245
Weight (kg):	195	306	482	563	645

## Deep-digging bucket

Specifications	DB02	DB02	DB03	DB05	DB06	DB07	DB09	DB11	DB12
Volume: (l)	70	90	120	160	200	250	350	400	500
Width: (mm)	450	550	550	600	600	700	700	700	800
Weight: (kg)	50	60	75	100	125	210	230	280	330
Attachment point:	S30	S40	S40	S40	S40	S45	S45	S45	S60
Base machine weight [t]:	1,5-3	1,5-3	2-4	4-6	5-7	6-8	8-10	10-12	11-13

Specifications	DB13	DB14	DB16	DB18	DB21	DB26	DB29	DB32
Volume: (l)	600	650	750	900	1100	1400	1,600	1800
Width: (mm)	850	900	1000	1000	1100	1,300	1450	1,700
Weight: (kg)	500	520	600	680	940	1330	1440	1720
Attachment point:	S60	S60	S60	S60	S70	S70	S70	S80
Base machine weight [t]:	11-13	13-16	15-17	17-20	19-22	24-27	27-31	31-33

## Cable bucket

Specifications	CB01	CB03	CB03	CB05	CB05	CB08	CB10
Volume: (l)	35	90	90	130	130	155	160
Width: (mm)	240	290	290	340	340	400	460
Weight: (kg)	25	55	55	70	85	95	160
Attachment point:	S30	S30	S40	S40	S45	S45	S45
Base machine weight [t]:	1,5-2	2-4	2-4	4-6	4-6	6-10	8-13

Specifications	CB15	CB15C	CB20	CB20	CB25	CB25	CB29	CB29
Volume: (l)	350	350	400	400	550	550	800	800
Width: (mm)	560	300	660	660	600	600	700	700
Weight: (kg)	290	255	320	360	590	615	744	777
Attachment point:	S60	S60	S60	S70	S70	S80	S70	S80
Base machine weight [t]:	13-17	13-17	17-22	17-22	22-27	22-27	27-33	27-33

## Ripper

Specifications	R06	R06	R12	R19	R26	R26	R33	R33
Height: (mm)	600	600	700	900	1,200	1,200	1400	1400
Weight: (kg)	50	65	110	170	370	410	680	720
Attachment point:	S30	S40	S45	S60	S60	S70	S70	S80
Base machine weight [t]:	1,5-6	1,5-6	6-11	11-18	11-30	11-30	18-33	18-33



## Sorting bucket

Specifications	SB02	SB02	SB04	SB06	SB06	SB08	SB11	SB14	SB15	SB17	SB20	SB24	SB29
Volume: (l)	90	130	200	300	300	370	500	650	750	900	1 100	1 400	1 600
Width: (mm)	900	900	1 000	1 200	1 200	1 300	1 400	1 600	1 600	1 700	1 700	2 000	2 000
Diameter: (mm)	22	22	22	22	22	30	30	30	45	45	45	45	45
Gap: (mm)	40	40	50	50	50	50	50	50	65	70	70	70	70
Weight: (kg)	80	91	144	166	177	292	320	442	628	697	920	1 046	1 268
Attachment point:	S30	S40	S40	S40	S45	S45	S45	S60	S60	S60	S70	S70	S70
Base machine weight [t]:	1,5-3	1,5-3	2-4	6-7	6-7	7-9	9-12	13-14	14-16	16-18	18-22	22-26	26-33

## Sorting bucket

Specifications	SKB02	SKB04	SKB06	SKB09	SKB14	SKB17	SKB23	SKB29
Volume: (l)	70	170	220	400	620	850	1 300	1 550
Width: (mm)	600	600	800	1 000	1 300	1 300	1 500	1 500
Gap: (mm)	44	41	47	51	62	62	62	62
Weight: (kg)	49	108	166	291	496	604	1 072	1 231
Attachment point:	S30	S40	S45	S45	S60	S60	S70	S70
Base machine weight [t]:	1,5-3	2-4	6-7	7-12	13-14	16-18	22-26	26-33

## Grading bucket

Specifications	GB02	GB02	GB03	GB04	GB05	GB05	GB06	GB06	GB08	GB08	GB11
Volume: (l)	90	130	150	200	250	250	300	300	370	400	450
Width: (mm)	900	900	1 100	1 000	1 200	1 200	1 200	1 200	1 300	1 400	1 400
Weight: (kg)	75	80	110	135	145	155	155	160	260	260	320
Attachment point:	S30	S30	S40	S40	S40	S45	S40	S45	S45	S45	S45
Base machine weight [t]:	1,5-3	1,5-3	1,5-3	2-4	4-5	4-5	6-7	6-7	7-9	7-9	9-12

Specifications	GB13	GB14	GB15	GB17	GB20	GB24	GB29	GB29
Volume: (l)	600	650	750	900	1 100	1 400	1 600	1 600
Width: (mm)	1 600	1 600	1 600	1 700	1 700	2 000	2 000	2 000
Weight: (kg)	450	460	660	700	980	1 150	1 460	1 490
Attachment point:	S60	S60	S60	S60	S70	S70	S70	S80
Base machine weight [t]:	12-13	13-14	14-16	16-18	18-22	22-26	26-33	26-33

## Water & sewerage bucket

Specifications	TB07	TB07	TB09	TB12	TB14	TB16	TB18
Volume: (l)	250	250	350	500	600	700	900
Width: (mm)	600	600	700	800	800	900	900
Weight: (kg)	202	213	250	340	510	550	750
Attachment point:	S40	S45	S45	S60	S60	S60	S70
Base machine weight [t]:	8-11	8-11	8-11	11-13	13-15	15-17	15-18

## Asphalt cutters

Specifications	TC03	TC06	TC12	TC19	TC33	TC33
Diameter: (mm)	Ø370	Ø370	Ø470	Ø470	Ø470	Ø470
Cutting depth: (mm)	100	100	150	150	150	150
Weight: (kg)	30	40	55	70	90	110
Attachment point:	S30/180	S40	S45	S60	S70	S80
Base machine weight [t]:	3-6	3-6	6-11	11-18	18-33	18-33



## **New functions for your excavator – new jobs for your company**

Do you want to work more efficiently and identify new business opportunities? engcon tiltrotators and tools are changing excavation worldwide.

With System engcon and EC-Oil you can quickly change tasks and increase both degree of usage and profitability of your excavator or backhoe loaders. System engcon products are compatible with one another and turn your excavator into a multi-tool for all kinds of tasks.

Dealers:

# **engcon<sup>®</sup>**